

INSTALLATION INSTRUCTIONS

Atplas boundary boxes are designed to comply with the relevant aspects of BS 5834 parts 1 and 2. Grade C and Grade B options are available. They are designed for conveyance of cold potable water only. No warranty is given nor liability accepted by Atplas for use for any other purpose, for failure to comply with these installation instructions, or for alterations made to the boxes. Atplas recommends the use of suitable protective clothing such as gloves, overalls, eye protection and safety footwear during installation.

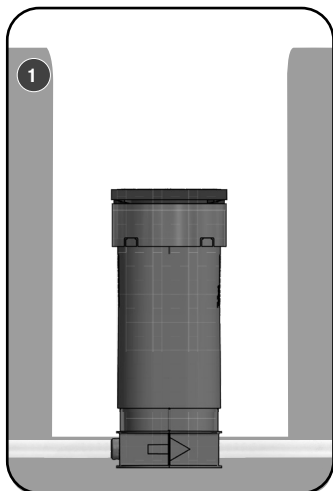

1. The service should be flushed fully to avoid any debris entering the system before connecting the service pipes.

Place the complete unit in an upright position, on firm even ground and connect the inlet and outlet pipe work (see back of this sheet). Avoid excess stress being placed on the connections. If necessary use additional fittings to align the pipes. The direction of the flow is indicated by an arrow on the base.

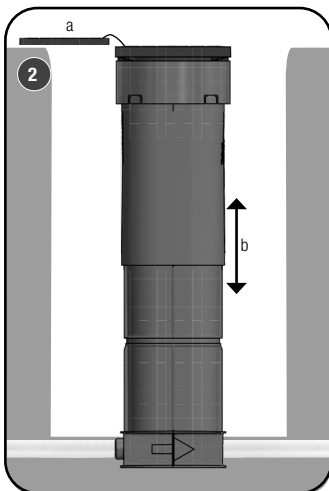

2. Open the surface box lid (a) to allow the telescopic chamber (b) to extend and adjust the box height to the approximate height of the final reinstatement level. The insulation pad must be fitted tightly in the boundary box to avoid water in the manifold freezing in very low temperatures.

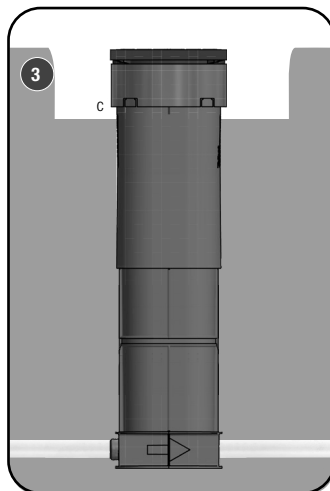

3. Close the lid and backfill with granular material in suitably compacted 100mm layers to the bottom of the surface box frame (c).

Notes: Where applicable reference should be made to the New Roads and Street Works Act 1991 and to HAUC regulations governing reinstatement as well as adhering to good general working practices.

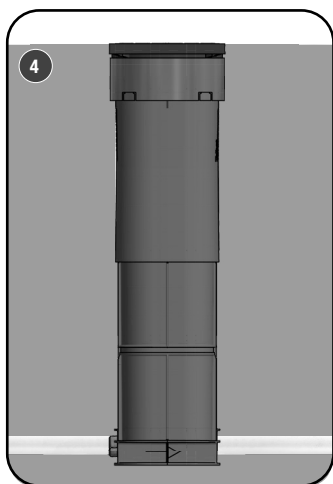

4. Prise lid to break the seal. Using the final adjustment available in the surface box frame, ensure the frame and cover meet the final level requirement. The surface box frame may be raised approximately 25mm above the final surface level then compacted down with the surrounding material, helping to improve reinstatement quality. Close the lid and continue to backfill up to a level below the top of the surface box that allows for the top surface material thickness, compacting the backfill. Finish to the final surface level. Ensure the surface box flange is supported by well compacted backfill in order to prevent lid settlement. Ensure that correct and accurate level and inclination are achieved to suit surrounding area to avoid potential trip hazards.

Note: For compaction and final reinstatement of the surface box, we recommend the use of contractors' rammers or similar hand tool.

Surface box options:

Grade C



Grade B



Grade B
(Ductile Iron)



Talbot Pushfit

