

MATRIX INLINE BELOW GROUND BOUNDARY BOX UNSEALED TELESCOPIC

25/32mm PE Connections Class 2.N.SBC.T 16 Bar pressure rating Class B load bearing



The Matrix Inline range of below ground meter boxes are products that are buried, usually in pavements and walk ways. The Inline range is for use with industry standard inline water meters to a length of 110mm and incorporates quick release meter mountings and a removable stop valve.

A large surface box opening provides excellent access and visibility into the chamber making meter reading, installation and maintenance simple. Matrix boxes are telescopic, height adjustable boxes manufactured from polypropylene. The surface box is rated to a 12.5t loading (EN124 Class B).

PRODUCT CODE	SURFACE BOX	CLASS	GUARD TUBE SHAPE	CONNECTION	SHUT OFF	HEIGHT
MAW7525SQ	Rectangular	2.N.SBC.T (Class B loading to EN124)	Oval	25mm Pushfit	¼ Turn	525-900mm
MAW7532SQ	Rectangular	2.N.SBC.T (Class B loading to EN124)	Oval	32mm Pushfit	¼ Turn	525-900mm

* Lid marked **'WATER'** and incorporates metal detector plate
 ** Available with beige guard tube on request

Matrix Inline Below Ground Boundary Box

MATRIX INLINE BELOW GROUND BOUNDARY BOX SEALED

25/32mm PE Connections Class 2.N.SBC.T 16 Bar pressure rating Class B load bearing

Feature	Specification
Frame and Cover	Universal 6° tilt. Pluck lid with oval or rectangular trim. Lid tether as standard. EN 124 Class B (12.5t loading) (polymer).
Guard Tube Material	Recycled Polypropylene
Guard Tube Profile	Stadium profile with 310mm x 202mm opening
Height Adjust (apr)	See below dimension table
Frost Protection	As standard in accordance with BS 5834-1:2017
Water Tightness	Unsealed Class 2
Shut Off Device	¼ turn spherical valve
Check Valve	In accordance with BS EN 13959: 2004 Family E Type B. (Double check valve also available)
Meter Connection	DN15 110mm long inline meter to BS EN ISO 4064; Q3 4.0. Requires flat faces on the meter for clamp connection.
Head Loss	< 3 metres @ 25 l/min flow rate with meter
Inlet	25/32 mm Pushfit for PE pipe in accordance with WIS 4-32-11
Outlet	25/32 mm Pushfit for PE pipe in accordance with WIS 4-32-11
Transit tube	Supplied with plastic transit tube to allow water to flow before meter is fitted.
Product Weight (apr)	tba
Pallet Quantity	tba
Accessories	WB226335CP: Ductile Iron surface box

The technical data and performance may be modified without prior notice depending on the technical advances.

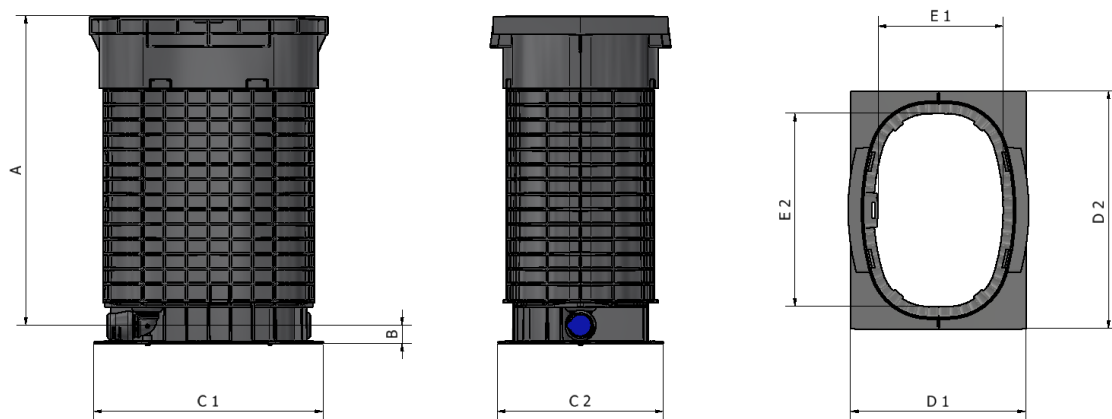

Box	A (min/max)	B	C1	C2	D1	D2	E1	E2
25mm Pushfit	498-868mm	29mm	368mm	266mm	281mm	383mm	202mm	310mm
32mm Pushfit	501-871mm	32mm	368mm	266mm	281mm	383mm	202mm	310mm